

CNC Grinding Center Model Evolution

High-Precision Tool Grinding Machine with 5 Axes

The newest dimension in tool grinding



Quality without compromise

The Model Evolution has been developed for the production of high-precision tools. The overall excellence of the machine occurs in the grinding of Micro-Tools.

Kinematics

The Evolution consists of 2 groups of axes, the grinding unit and the workhead unit. They are mounted onto a cast iron base plate. The base plate is supported by special anti-vibration pads, to avoid interferences from external sources. The grinding unit (A & Y-axis) controls movement of the grinding wheels. The workhead unit (U, V, X and Z-axis) controls movement of the tool. The U-axis has dual functionality: it can be used as a positioning axis or a free-turning spindle (used when cylindrical grinding). The TTB kinematic allows the wheels to grind above or below the tool. The thermal stability of the machine components is guaranteed by the use of temperature controlled fluids.

The heart of the machine is the spindle turret, consisting of 4 spindles. Each spindle can be equipped with up to 3 different grinding wheels. This feature provides the machine with important advantages:

- All required grinding wheels are always and instantly ready for use in the machine.
- The selection of the grinding wheel is performed in seconds.
- Absolute accuracy in positioning and repeatability.

The tools can be ground in one clamping and with the highest degree of precision. Additionally, the linear axes have a "one of a kind" motion-driving system; a combination of hydrodynamic technology and a calibrated preload. The conclusion: guaranteed unparalleled repeat accuracy and backlash-free movements of less than 0.0004 mm.

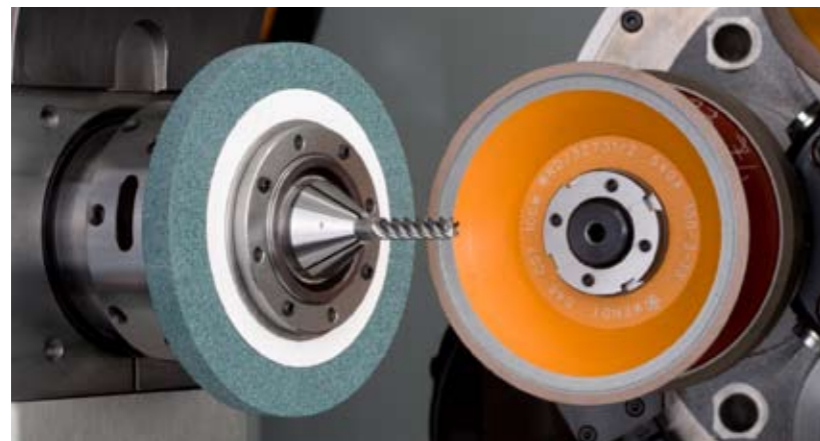
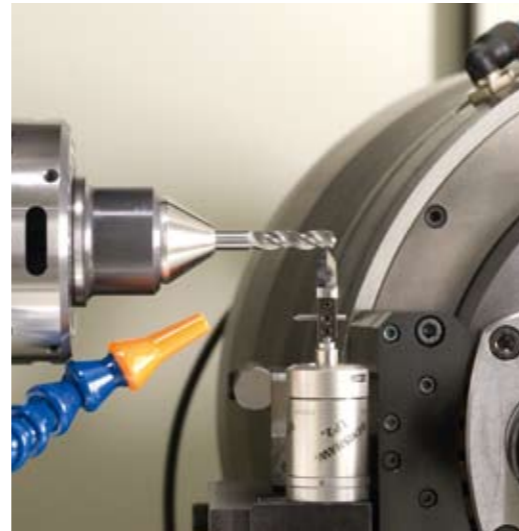

Micro-tools

Tools having diameters in the range of 0.02 mm to 14 mm are ground in optimal Quality. Resharpener is also possible for tools having diameters upwards to 25 mm.

Setup of the Machine

For setup of the Evolution, there are choices of various workpiece spindles, clamping systems, wheel spindles and wheel flanges. This allows individual configurations and optimization of the machine for a specific grinding task. Changing of the modular units happens easily and quickly. The tool measuring probe is standard equipment for the machine. The grinding wheels can be trued and measured while mounted inside the machine.

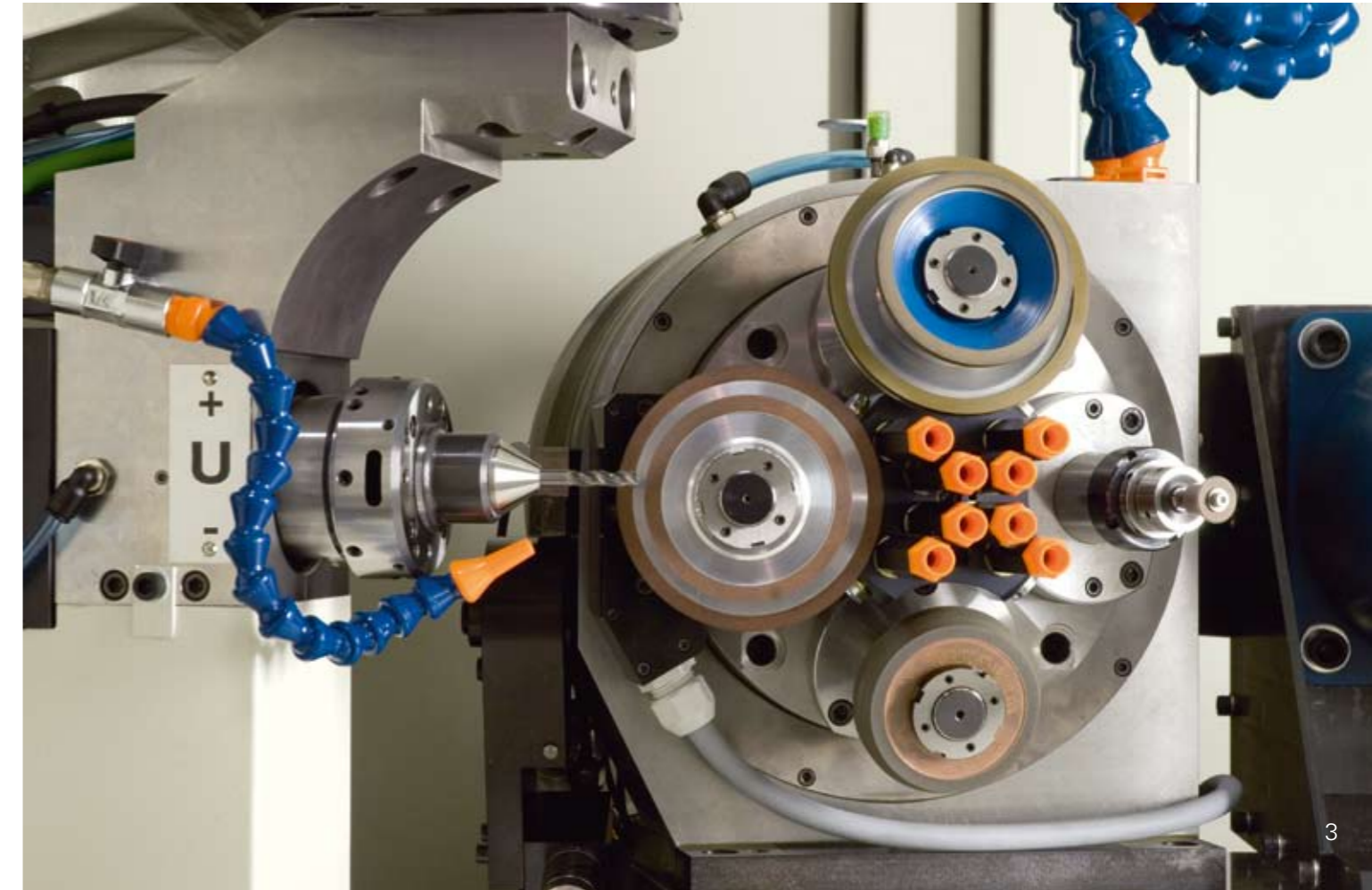
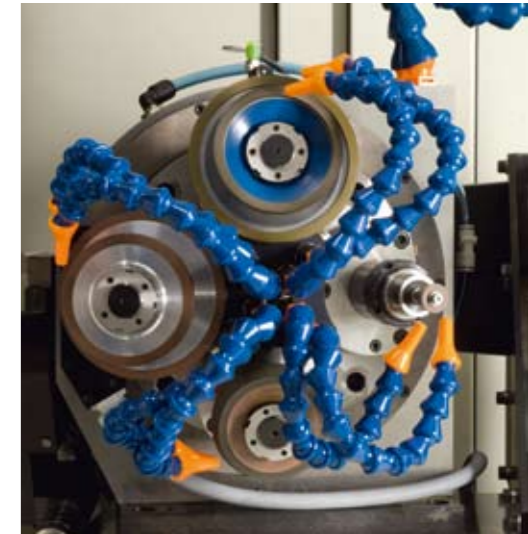

Profitability through high automation

The machine can be equipped with an automatic tool loading unit, allowing 24/7 and un-manned operation.

Tool Loading Unit with High Capacity

The tool loading unit consists of 2 accurate CNC-Axes (X2 & Y2), as well as pneumatic motion and clamping units.

The tool loading unit consists of dual pallets and dual grippers. During a single loading sequence, a new blank is taken from the 1st pallet by gripper #1 and awaits completion of the grinding cycle. Once grinding has completed, the tool loading unit enters the machine, removes the finished tool with gripper #2, inserts the new blank into the collet and exits the machine. The finished tool is then placed into pallet #2.

The TTB standard pallets (tool diameters from 1 to 16 mm) can contain upwards to 814 tools, which depends on the tool diameter. Customer-specific solutions, such as special pallets or loading sequences can be provided upon request.



Flexibility by a multitude of accessories

TTB can supply special peripheral equipment, accessories and special units upon request

- Coolant filter and supply pump units
- Tanks and transfer pumps
- Chillers
- Oil mist filtration systems
- Fire protection systems
- Optical measuring systems for grinding wheels
- Image processing for tool positioning
- Special measuring systems with laser or probe technology
- Assembly units for specific applications
- Special loading units

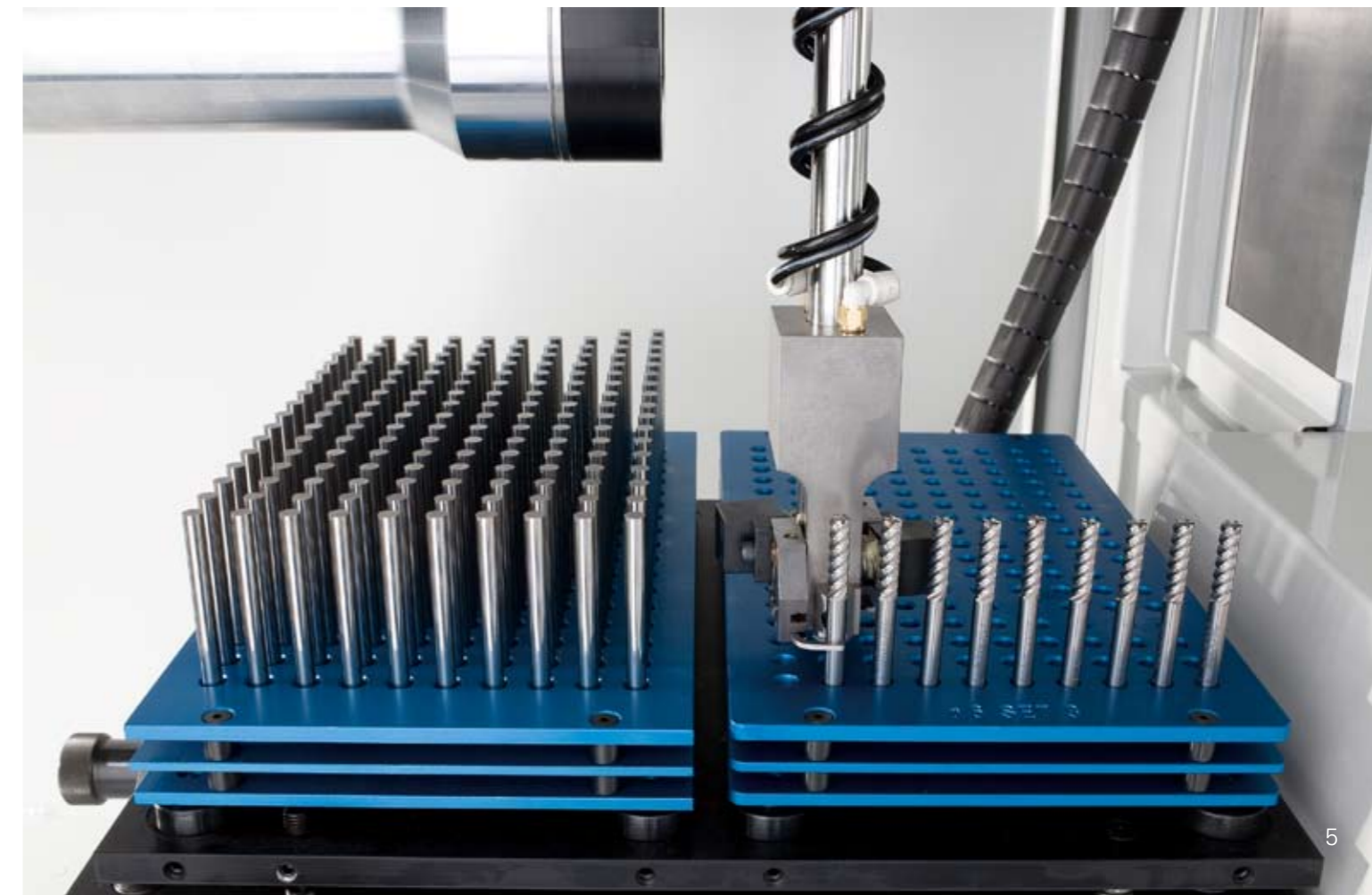
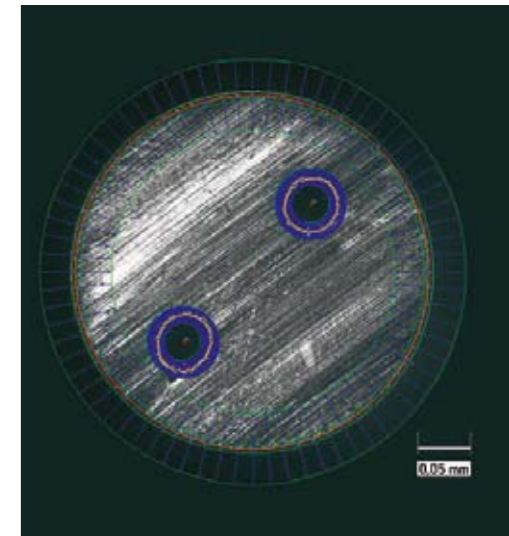

Solutions for all applications

Steady Rest

The automatic steady rest is demanded for tools having a grinding length ratio greater than 10 to 15 times the diameter.

The mounting and setup is performed easily and quickly. The support inserts are held by a quick clamping system and can be aligned to the taper angle.

High Frequency Spindle

The high frequency spindle is used for the grinding of pockets of inserts and for grinding with small diameter wheels. The HF spindle can be mounted in the place of a standard spindle.

The spindle turret can even host several HF spindles.

Machine Control

The Model Evolution is configured with the CNC control Num. This allows for customisation of your grinding strategies, as well as compatibility with your existing Programmers and/or Operators Know-How.

The CNC control has its own unique drive technology and programming System.

NUM Software

NUMROTOplus® with 3D Simulation and Collision Detection

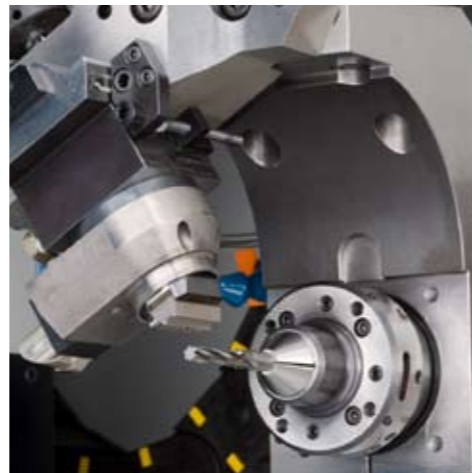

Technical Specifications

Linear Axes	
Longitudinal Travel – X Axis	290 mm
Cross Travel – Y Axis	250 mm
Vertical Travel – Z Axis	150 mm
Swiveling Axis	
Swiveling Range of Workhead – V Axis	240 °
Rotary Axes	
Rotation Range of Tool	
U Axis	infinite
Rotary Speed – U Axis for cylindrical grinding	0 – 2'500 rpm
Feedrates	
Linear Axes – X, Y, Z Axes	3 m/min
Swivel of Tool Spindle – V Axis	10'000 °/min
Rotary speed	
U Axis as a positioning Axis	36'000 °/min
Minimum Positioning Increment	
Linear Axes – X, Y, Z Axes	0.0001 mm
Rotary Axes – U, V Axes	0.0001 °
Accuracy for repeating and positioning	
Linear Axes – X, Y, Z Axes	+/- 0.001 mm
Swivel Axis – V Axis	+/- 0.001 °
Rotary Axis – U Axis	+/- 0.002 °
Turret and Wheel Grinding Spindles	
Number of Grinding Wheel Spindles	4
Power of Grinding Wheel Spindle Motor	3,7 kW S1
Programmable Speed of Grinding Spindles	up to 12'000 rpm
Number of possible Wheels per Spindle	1 – 3
Positioning Time of Turret	3 sec
High Frequency Spindles	60'000 rpm
Tool Clamping	
Clamping Systems	W25, W20, B15, B12 Hydraulic Collet
Clamping Diameter Range	1 – 25,4 mm
Clamping Length	up to 250 mm
Optional Clamping Systems	upon request
Application Technology	
Grinding from Solid Material	ø 0,02 – 14 mm
Resharpener	ø 3 – 25 mm
Grinding Length	max. 150 mm
CNC Control	
	Num
Dimensions of Machine (see layout above)	
	290 x 220 x 185 cm
Weight	
	3'800 kg

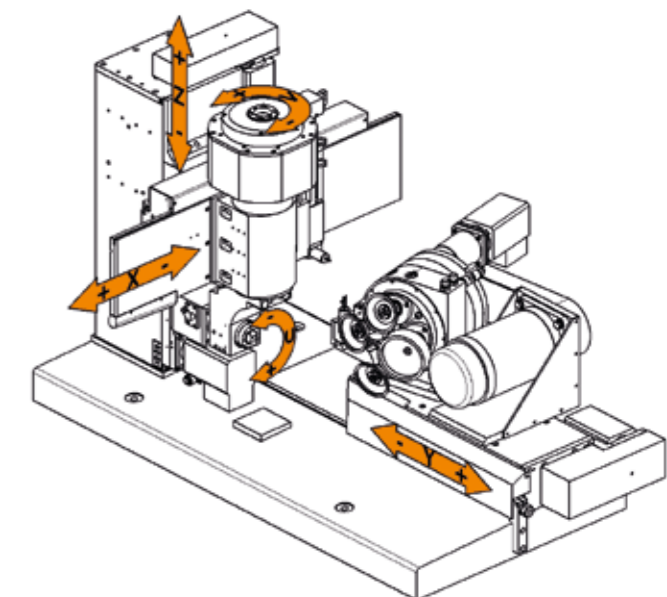
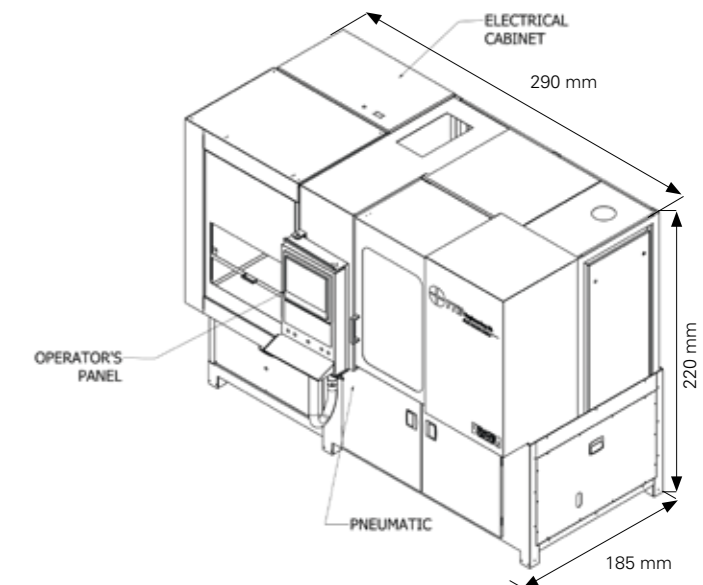

We reserve the right to make changes to the product delivered compared with the data and illustrations in this catalogue.



TTB Engineering SA
Via Industria 9
CH-6826 Riva S. Vitale
Phone (+41) 91 / 640 20 30
Fax (+41) 91 / 630 50 49
www.ttb-eng.com
info@ttb-eng.com

